

No. 119,939.

PATENTED OCT. 17, 1871.

G. MERRILL.
BREECH LOADING FIREARM.

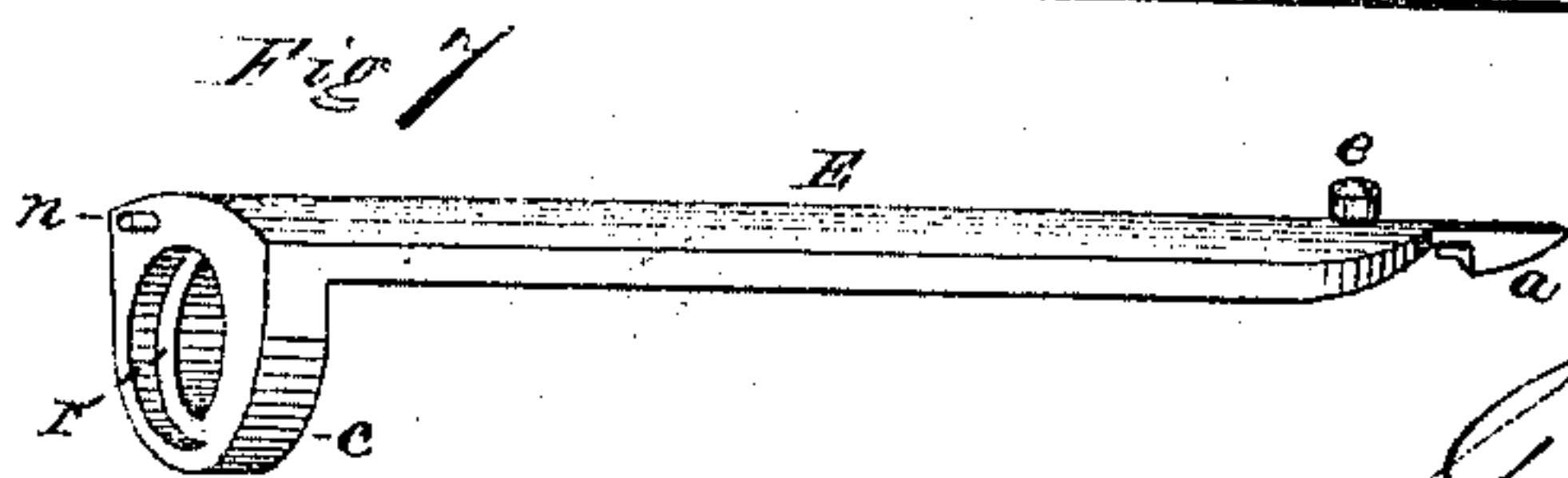
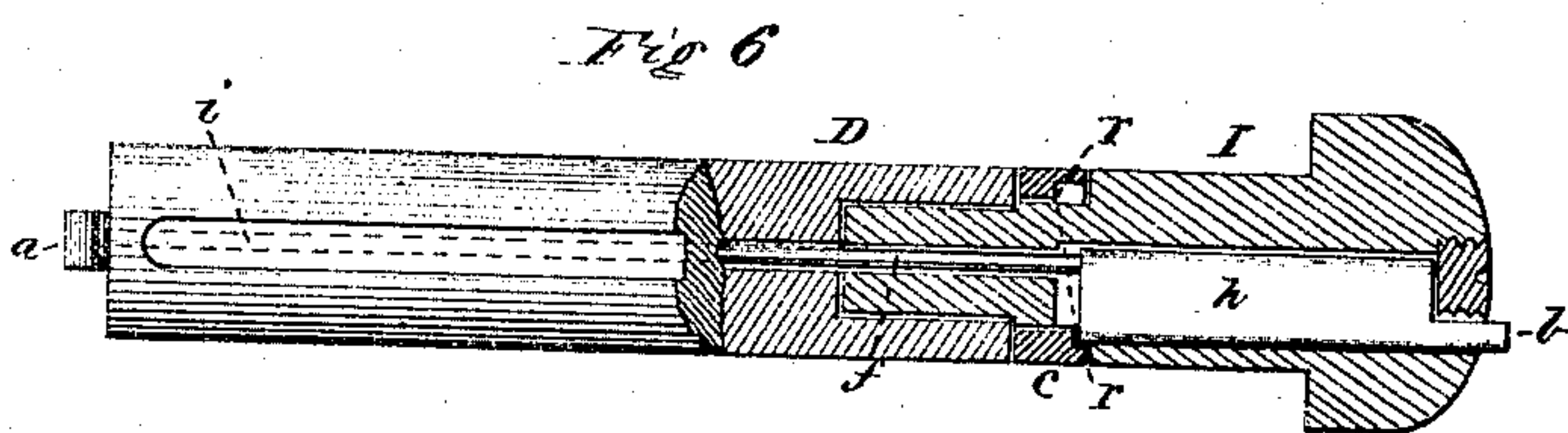
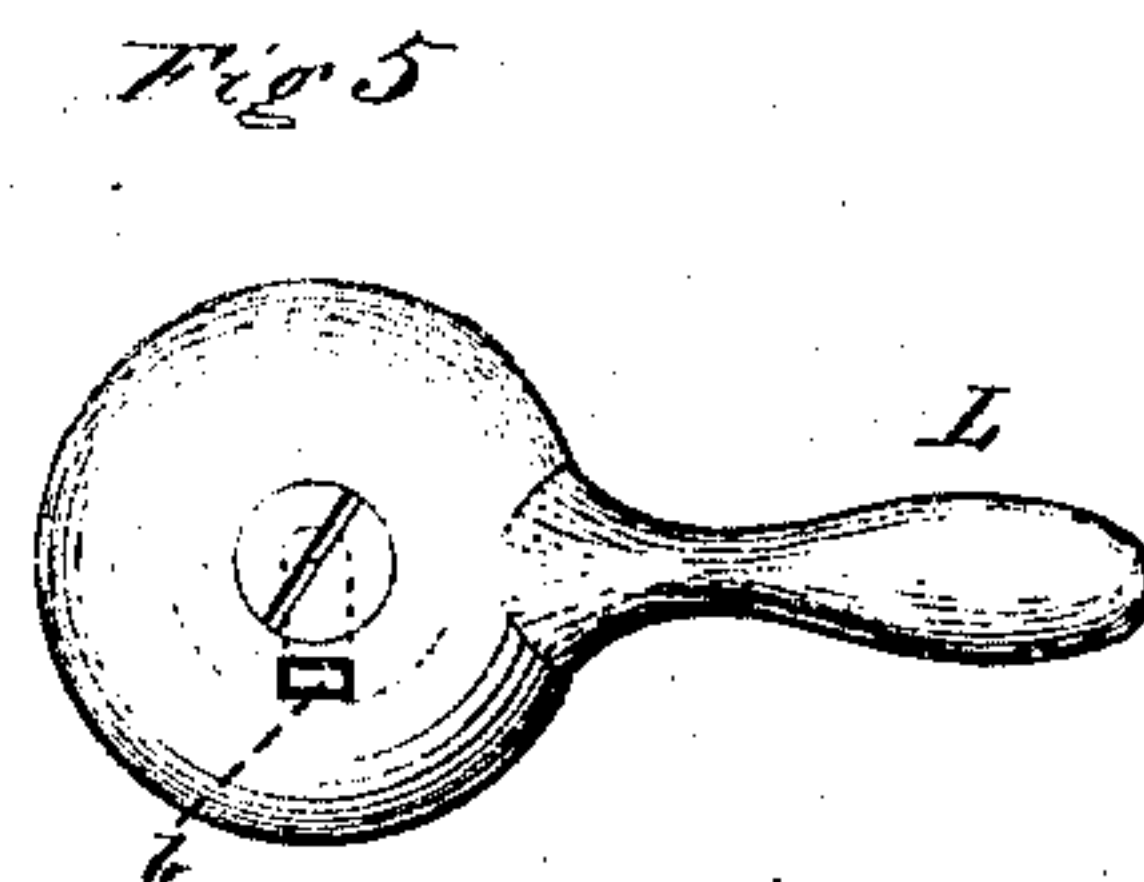
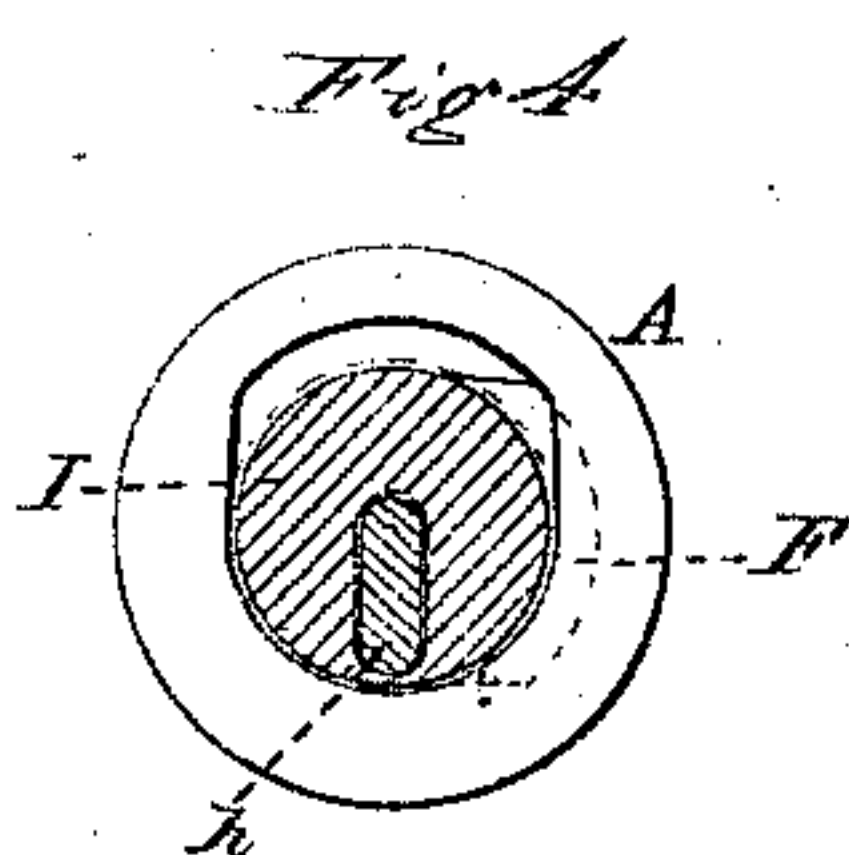
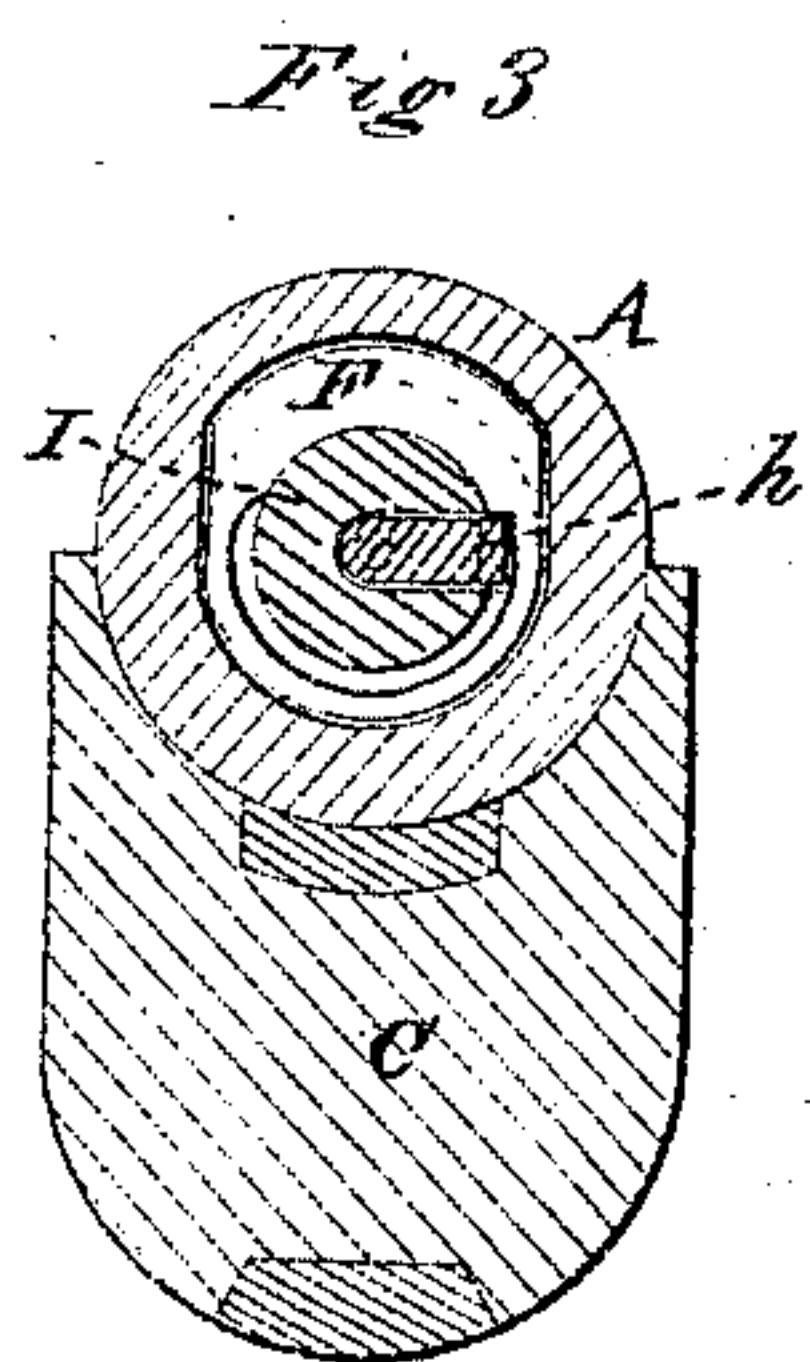
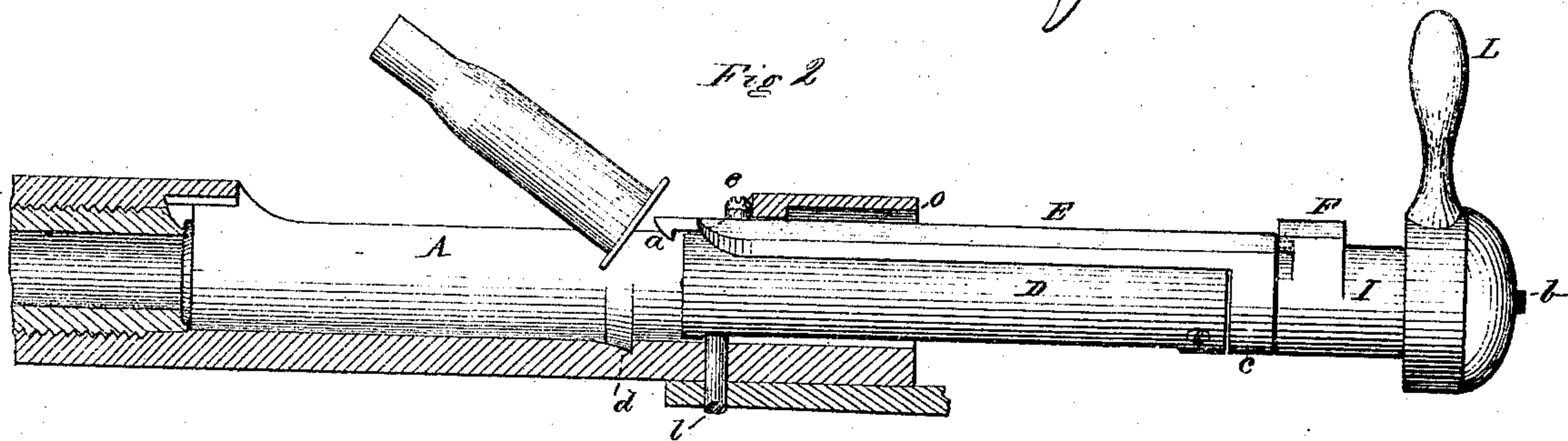
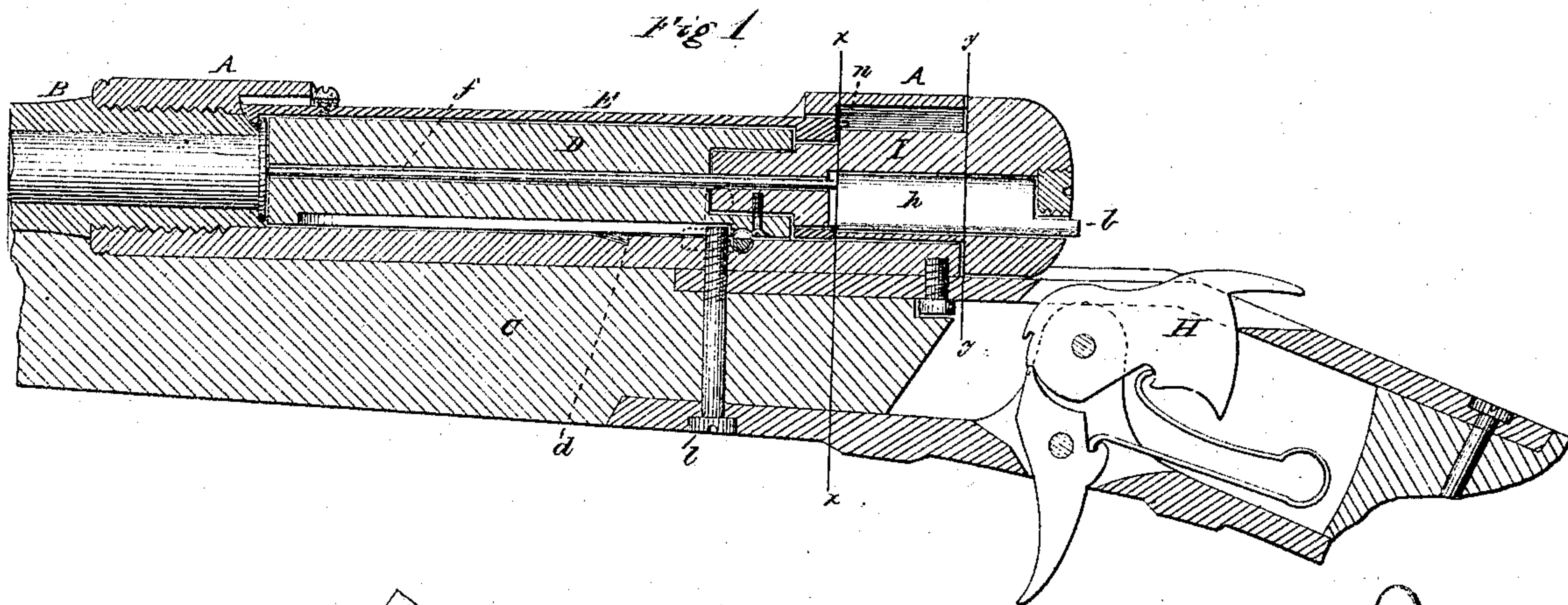

Witnesses

Jerry King
Phil T. Dodge

Inventor

Geo. Merrill
by Dodge & Munn.
Attys.

UNITED STATES PATENT OFFICE.

GEORGE MERRILL, OF EAST ORANGE, NEW JERSEY.

IMPROVEMENT IN BREECH-LOADING FIRE-ARMS.

Specification forming part of Letters Patent No. 119,939, dated October 17, 1871.

To all whom it may concern:

Be it known that I, GEORGE MERRILL, of East Orange, in the county of Essex and State of New Jersey, have invented certain Improvements in Breech-Loading Guns, of which the following is a specification, reference being had to the accompanying drawing.

My invention relates to that class of breech-loading guns which has a movable or sliding bolt, arranged to operate as a breech-block; and the invention consists in certain novel features pertaining to the breech mechanism and extractor, as hereinafter more fully explained.

Figure 1 is a longitudinal vertical section of the rear portion of a gun made on my plan, with the breech closed. Fig. 2 is a similar view of a portion with the breech open, and illustrating the manner of ejecting the cartridge-shell. Figs. 3 and 4 are transverse sections on the lines $x x$ and $y y$, respectively, of Fig. 1. Fig. 5 is a rear end view, and Figs. 6 and 7 are views of portions shown more in detail.

In constructing my gun I provide a barrel, B, which is screwed into the front end of a receiver, C, which latter is hollowed or bored out longitudinally in line with the bore, and which has also an opening or slot cut in its upper side of sufficient length to receive the cartridge, as represented in Figs. 1 and 2, these parts being similar to many other guns of this class in their general character or construction. I then provide a breech-plug, which I make as follows: The front part, D, consists of a cylindrical bolt of proper size to fill the chamber of the receiver A, with a longitudinal recess cut in its under surface, as shown in Figs. 1, 2, and 6. The rear part consists of a similar bolt, having a cam, F, projecting from one side to lock into a corresponding recess, o , in the receiver, as shown in Fig. 2. To the rear end of this part I is secured a rounded head, having a lever or handle, L, projecting from one side to operate in the usual manner. The parts D and I are united as shown in Figs. 1 and 6, and at their point of union an annular recess is formed on one of them, in which is fitted loosely a collar, c , which is part of or attached to the retractor E, which, as shown in Figs. 1 and 2, consists of a thin bar fitted to lie loosely upon the upper side of the part D, this bar E terminating at its front end in a hook, a , which projects slightly beyond the front end of the plug

D, and has its point beveled, as represented in Figs. 2 and 7. This bar E is intended to be formed so as to spring in its length sufficiently to permit the hook a to ride up over the flange of the shell in the chamber of the gun, there being a recess formed in the receiver at the proper point, as shown in Fig. 1. This bar E, being thus loosely attached to the plug by the collar c , moves back and forth with the breech-bolt or plug, the receiver at its rear end being cut away on the under surface of its upper side to form a groove corresponding to the form and size of the bar, as shown in Figs. 3 and 4; but, being held in this groove, it does not turn over with the breech-bolt. A hole is bored centrally through the parts D and I to receive the firing-pin, the front portion of which consists of a straight pin, f , as shown in Figs. 1 and 6, but which, near its rear end, is enlarged into the form of a flat piece, h , the body of which projects laterally in a corresponding recess cut in the part I, its rear end terminating in a small projection, b , which projects through an opening in the rear end of the breech-bolt, this end b being eccentric to the front portion f , as shown clearly in the figures referred to, 1 and 6. As shown in Fig. 7, an incline, r , is formed on the rear inner face of the collar c , and, as shown in Fig. 6, this incline bears against the front shoulder of the flat part h of the firing-pin, and as the firing-pin is turned, with the breech-bolt, while the bar E, with its collar, c , and incline r remains stationary, it follows that, in turning the bolt to unlock it, the firing-pin is forced back by the incline, and thus the firing-pin is retracted or drawn back so that its front end is within the bolt when the latter is drawn back, and so remains when the breech is closed; hence there is no danger of the firing-pin hitting and exploding the cartridge in closing the breech. A pin or screw, l , extends from below up through the trigger-stop, stock, and receiver, as shown in Fig. 1, and has its end working in the longitudinal groove i , in the under side of the breech-bolt, thus serving both as a guide and also as a stop to prevent the bolt from being drawn entirely out. A small screw, e , is also inserted in the top of the bar E, near its front end, which also serves as a stop by striking against the rear portion of the receiver, as shown in Fig. 2. By extending the groove i out to the front end of the breech-bolt it will

enable the latter to be drawn entirely out without withdrawing the screw *l*; or if the groove be made as shown in Fig. 1, with the end of the screw *l* fitting therein, then the screw *e* may be dispensed with; so that in either case it is only necessary to take out a single screw to remove the breech-bolt. It will be seen that as the retractor-bar *E* lies in the opening in the top of the receiver when the breech-bolt is shoved in, and is only connected to the latter by the collar *c*, its front portion is free to rise, so that its hook *a* will ride over the flange of the cartridge and engage thereon as it is shoved forward, the bar either being formed so as to spring sufficiently for this purpose; or, if made stiff, it being sufficiently loose where pinned to the breech-bolt to permit its front end thus to rise. At the same time, as the breech-bolt is drawn back, the retractor-bar is held firmly down upon the bolt by the wall of the receiver above it, and thus the hook is prevented from slipping off the flange of the shell. In the bottom of the receiver, near its rear end, and just in front of the point where the front end of the breech-bolt stops when drawn back, I cut a recess, *d*, the rear wall of which is at right angles, while its front is beveled or inclined forward, as shown in Fig. 2. It will thus be seen that as the shell is drawn back by the hook *a* the under side of its head will drop into this recess, and, striking against its rear or vertical face, will be held by it; while its upper portion being drawn back by the hook, it will be tilted and thrown out of the receiver, as represented in Fig. 2, the hook being pressed or held down, and prevented from slipping off of the flange of the shell by the pressing upon it of that portion of the receiver under which the bar *E* slides, as previously described. It is obvious that instead of the recess *d* the chamber of the receiver may be roughened at that point by a series of smaller grooves, and made to answer the same purpose, though not as well. The hammer *H* is located in rear of the

breech-bolt, and at such a height that, when cocked, the bolt can slide over it, as shown in Fig. 1. It is also located centrally in line with the firing-pin, so that when the breech is closed the hammer, when released, will strike against the projecting end *b* of the pin, and thus ignite the charge. At the same time, when the breech-bolt is turned partially over to unlock it preparatory to drawing it back, the end *b* of the firing-pin will be turned to one side out of line with the hammer, and thus the hammer cannot bear against it while the breech is being opened, nor can it hit it accidentally until the breech is closed and locked. It will also be seen that by thus locating the hammer the latter will be forced back and cocked by the act of drawing back the breech-bolt, the rounded head of the latter striking or pressing against it as it is drawn back, thus saving the usual motion required to cock the gun.

By this method of constructing a gun I make one that is exceedingly simple in its parts and operation, and that is safe to handle.

Having thus described my invention, what I claim is—

1. The extractor-bar *E* secured to the breech-plug *D* by means of the collar *c*, the latter being provided with the incline *r* for forcing back the firing-pin, as set forth.

2. The combination of the sliding breech-plug *D*, the firing-pin having the eccentric or shoulder *b*, and the ring or collar *c* having the incline *r* thereon, all constructed and arranged to operate as set forth.

3. The sliding breech-plug *D* in combination with the eccentric firing-pin and the hammer *H*, arranged in rear of said breech-plug, whereby the end of the firing-pin is thrown out of line with the hammer, and the hammer is cocked by the movements in opening the breech.

Witnesses:

GEO. MERRILL.

N. E. PRINCE,

JOHN H. MOONEY.

(18)